

Seat Belt Anchorage Frame



DA3554
Seat Belt Anchorage Frame

Series 2
Series 2A
Series 3
Defender



Note - Will NOT fit a Lightweight or Series 1
This Safety Devices seat belt anchorage frame is designed to provide a robust belt mounting in Soft Top models. Manufactured from 38.1mm x 2.64mm seamless tube, the frame provides both upper inertia seat belt reel mounting points and also provides upper harness mounting points when wrapped around the tube. The frame fits directly over the existing canopy support brackets and has rearwards supports which also mount to the capping.

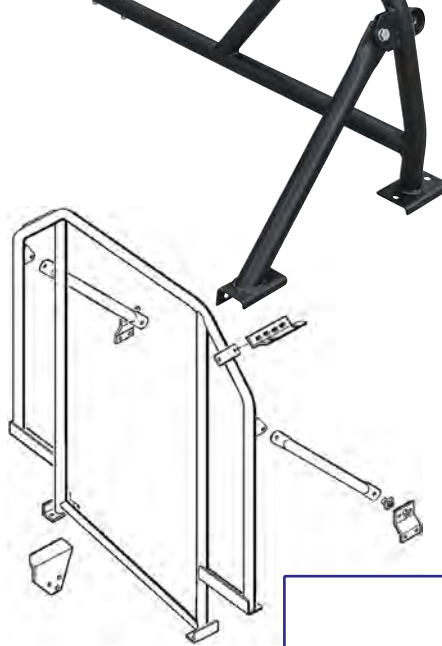

XS Brake Discs



LR083647G
Discovery Sport - 2015 onwards
Range Rover Evoque
- 2012 - 2018
Front
Vented



RBL0334SSS/A
4-point bolt-in single hoop roll bar
Black

Without diagonal. For bulk head models only. We strongly recommend fitting the roll cage padding kit when installing this roll cage.
Defender 90 - Td5 Hard Top & Station Wagon - 3-door - 1998 - 2006
Defender 90 - 300Tdi Hard Top & Station Wagon - 3-door - 1994 - 1997
Defender 90 - 200Tdi Hard Top & Station Wagon - 3-door - 1990 - 1993
90 - Hard Top & Station Wagon - 3-door - 1983 - 1990

RBL033PAD **Internal roll cage padding**
Black
For roll-cage kit RBL0334SSS/A

Safety Devices Roll Cages

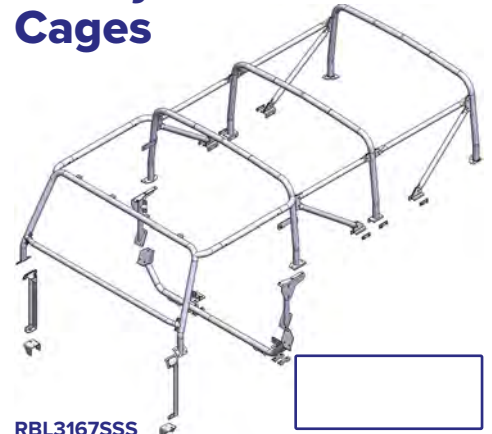

RBL3167SSS
External/Internal 12-point bolt in external/internal roll cage

External front cage that passes through the canvas behind the door to join the internal section. Rearward mounted B hoop, so requires 1 x OEM hood stick in front of B hoop to mount door hardware to. Designed to be used only on vehicles equipped with OEM/Land Rover bulkhead replacement bar - it may not work with after-market alternatives. We strongly recommend fitting the roll cage padding kit when installing this roll cage.
Defender 110 - Td5 2-door Soft top - 1998 - 2006 without bulkhead behind seats
Defender 110 - Puma 2-door Soft top - 2007 - 2015 without bulkhead behind seats

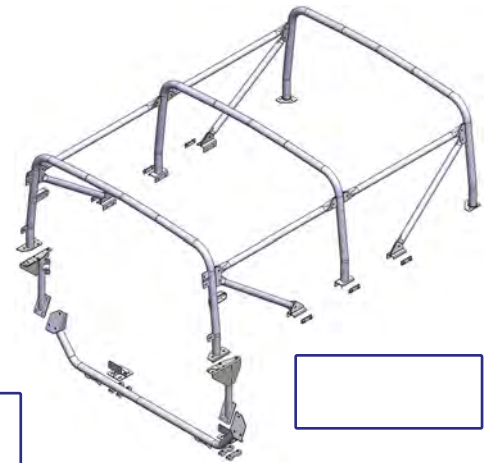

RBL3177SSS
Heavy-duty 10-point bolt-in internal rear heavy duty hood stick replacement.

Forward hoop position, so B hoop includes front seat belt upper anchor points, mountings for door frame hardware and backstays that mount to the capping. Rear hoop includes upper and lower mountings for forward facing seats. Designed to be used only on vehicles equipped with OEM/Land Rover bulkhead replacement bar - it may not work with after-market alternatives. We strongly recommend fitting the padding kit when installing this heavy-duty hood stick replacement.
Defender 110 - Td5 2-door Soft top - 1998 - 2006 without bulkhead behind seats
Defender 110 - Puma 2-door Soft top - 2007 - 2015 without bulkhead behind seats

Safety Devices Roof Racks

RRL2290FRS

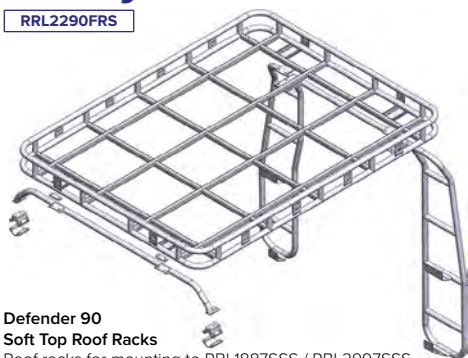

Defender 90 Soft Top Roof Racks

Roof racks for mounting to RBL1887SSS / RBL2997SSS.

Defender 110 4-door Soft Top Roof Racks

Roof racks for mounting to RBL3087SSS.

Rack covers the full length of vehicle.

Kit includes double rear ladder and cross rail.

RRL2290FRS	2.0m x 1.4m	Full luggage rail
RRL2290LRS	2.0m x 1.4m	Long luggage rail
RRL2290SRS	2.0m x 1.4m	Short luggage rail
RRL2290NRS	2.0m x 1.4m	No luggage rail

RRL2290LRS

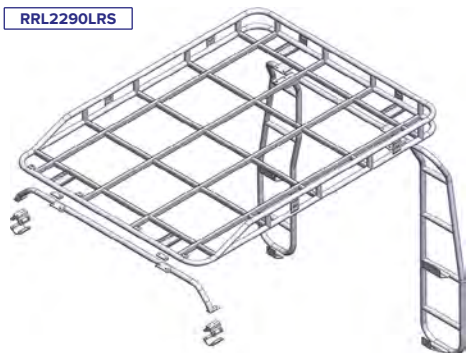

RRL2320SRS

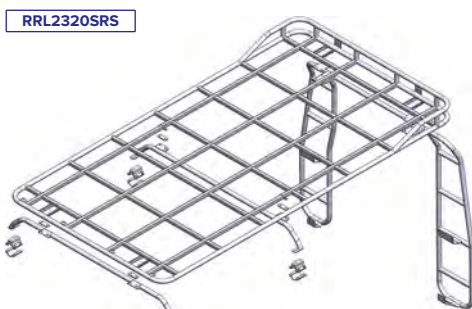

Defender 110 4-door Soft Top Roof Racks

Roof racks for mounting to RBL3087SSS.

Rack covers the full length of vehicle.

Kit includes double rear ladder and cross rail.

RRL2320FRS	2.8m x 1.4m	Full luggage rail
RRL2320LRS	2.8m x 1.4m	Long luggage rail
RRL2320SRS	2.8m x 1.4m	Short luggage rail
RRL2320NRS	2.8m x 1.4m	No luggage rail

RRL3156SSS

Double rear ladder which mounts to existing fixings in the rear crossmember and also to the capping either side of the rear door. Designed to allow the fitment of an Explorer roof rack to a Soft Top vehicle fitted with the following Safety Devices Internal/External roll cages:

- RBL1887SSS Defender 90 - 2-door
- RBL2997SSS Defender 90 - 2-door
- RBL3087SSS Defender 110 - 4-door

The ladder is used in conjunction with the following front cross rails:

- RRL315-RR-CC-XRA
- RRL315-RR-CC-XRB

Price from...



RRL2450NRS

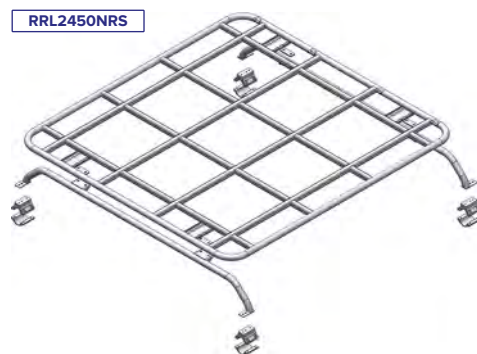

Defender 110 4-door Soft Top Roof Racks

Roof racks for mounting to RBL3087SSS.

Rack mounts to front external cage only, covering the front half of the vehicle, not over the rear.

Kit not suitable for double rear ladder

RRL2450FRS	1.6m x 1.4m	Full luggage rail
RRL2450LRS	1.6m x 1.4m	Long luggage rail
RRL2450SRS	1.6m x 1.4m	Short luggage rail
RRL2450NRS	1.6m x 1.4m	No luggage rail



Suspension Arm & Bolts Kits

LR019977K

Range Rover Sport - 2010 - 2013
Rear - lower RHS

LR019978K

Range Rover Sport - 2010 - 2013
Rear - lower LHS



LR063718K

Range Rover Sport - 2005 - 2013
Rear - upper LHS

LR063719K

Range Rover Sport - 2005 - 2013
Rear - upper RHS



Meyle Suspension Arm & Bolts Kits

Steering and suspension components are subject to extremely high load levels, which frequently results in increased part wear and shorter replacement intervals. Required to perform reliably under these conditions, the parts are therefore made to genuine Meyle heavy duty quality which means optimised products offering maximum service life and outshining OE solutions.

LR073367HDK

Discovery 4 Front - lower RHS

LR073369HDK

Discovery 4 Front - lower LHS

LR075993HDK

Discovery 3 Front - lower RHS

LR075995HDK

Discovery 3 Front - lower LHS



Price from...

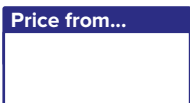

uksales@britpart.co.uk

Available from...

Britpart, The Grove, Craven Arms, Shropshire, SY7 8DA www.britpart.com

Prices include VAT. Part numbers are used for identification purposes only and do not imply or indicate the identity of the manufacturer. E&OE.



Traxxas 1/10th Scale Defender

Watch them go... www.britpart.com/traxxas-10



Many more images and information can be found online at www.britpart.com

- DA3640** TRX-4 Defender 1:10 Blue
- DA3641** TRX-4 Defender 1:10 Grey
- DA3645** LED Light Set
- DA3649** Charger
- DA3650** Battery

Take The Path Less Travelled

The Traxxas TRX-4® Scale and Trail® Crawler is an all-new Traxxas design that is loaded with innovation that instantly obsoletes the status quo with exciting new features, versatility, and capability. In other words, we built it the Traxxas way, rugged, powerful, and ready for fun! Underneath the authentic scale look is a machine built for extreme off-road capability that takes you to new places and new adventures. Exclusive portal axles deliver maximum ground clearance that dramatically turns "no way" into "no problem." Whether you are enjoying outdoor trails or getting technical on the rocks, the remote-locking front and rear differentials and high/low range transmission provide unmatched driving versatility.

What's In The Box

- > TRX-4, Ready-To-Race® model
- > XL-5 HV waterproof electronic speed control
- > Titan™ 21T reverse rotation motor
- > TQi™ 2.4GHz radio system with cruise control
- > High quality maintenance tools

Innovation

Radically innovative technology combines with precision engineering to create a completely new breed of Scale and Trail® Crawler...Only from Traxxas.

GTS Aluminum Shocks

All new oil-filled coil-over GTS shocks deliver silky-smooth damping performance and feature threaded aluminium shock bodies for easy ride height adjustments. The convincing scale realism looks great and they perform even better.

High/Low Range Transmission

When the going gets tough, shift into low range for incredible 4WD pulling torque. Shift into high range for blasting down the trail. The TRX-4 Scale and Trail Crawler adapts to any situation or driving style.

3S Power System

The new XL-5 HV electronic speed control brings 3S LiPo capability for stronger, more efficient running. The powerful 217 Titan® motor provides torque to tackle the steepest climbs and all-out speed on flat terrain. This efficient system provides up to 2 hours of run time with a Traxxas 35 5000mAh iD LiPo battery pack!

TOI Radio System With Cruise Control

The Traxxas TOI; features our exclusive cruise control for long-

What You'll Need

- > Batteries - TRX-4 accepts a wide variety of NIMH (4-7 cell) and LiPo (2s-3s) batteries.
- > Charger - Traxxas EZ-Peak Live charger is recommended for easy and fast charging performance (model #2971).
- > 4 x AA Alkaline batteries for the transmitter.

Vehicle Specs

- > Length: 586mm
- > Front Track: 249mm
- > Rear Track: 249mm
- > Ground Clearance: 80mm
- > Weight: 3.372kg
- > Height: 292mm
- > Wheelbase: 324mm
- > Approach Angle: 56.49°
- > Departure Angle: 41.67°
- > Breakover Angle: 57°
- > Front Shock Length: 90mm
- > Rear Shock Length: 90mm
- > Front Wheels: 49 x 26mm
- > Rear Wheels: 49 x 26mm
- > Front Tyres: 118 x 48mm
- > Rear Tyres: 118 x 48mm

distance treks. Set your speed using the transmitter and then use the multi-function knob to fine-tune it faster or slower to match precisely the pace of your caravan of trail explorers.

Accessory Light Kits

Optional light kits illuminate the trail ahead and provide an authentic appearance. A separate regulated power supply ensures powerful lighting with consistent brightness. (All light kits and light kit accessories are sold separately.)

Waterproof Electronics

The TRX-4 is fully waterproof, not 'splash resistant.' There is a big difference. Traxxas' patented innovation gives you the freedom to tackle creeks, snow, and mud without worrying about water in your electronics.

The Power Of Portals

Portal axles lift the truck at the wheels for huge centre pumpkin ground clearance. In order to achieve the same clearance with straight axles your tyres would have to be over an inch taller than the tyres on the TRX-4.

Torque Twist Eliminated

The portal axles use gear reduction at the wheels to virtually eliminate torque twist. The Titan 550 motor's torque translates into straight powerful, forward motion, rather than wasted energy twisting your rig right off the rocks.



All-New Chassis Design

The Traxxas TRX-4 Scale and Trail® Crawler is an all-new design that instantly obsoletes the status quo with greatly expanded features, versatility, and capability. Performance and technology combine in a revolutionary new chassis that looks as good as it performs.

Rigid Steel Frame

A heavy-duty formed-steel ladder frame with moulded cross members creates an extremely rigid backbone. You'll feel the difference on trails when navigating technical terrain.

Scale Details

The TRX-4 features a fully licensed and highly detailed Land Rover Defender body. Scale details abound from the detailed front grille and bumper to the functional spare tyre in the back. Realistic lighting details, side mirrors, bumpers and even the included jack all add to the rugged and authentic appearance.

Remote Locking Differentials

Traxxas allows you to lock and unlock both the front and rear differentials remotely from your transmitter. New sleeved micro cables control the differential action for scale appearance, without limiting suspension articulation.

uksales@britpart.co.uk

Available from...

Britpart, The Grove, Craven Arms, Shropshire, SY7 8DA www.britpart.com

Prices include VAT. Part numbers are used for identification purposes only and do not imply or indicate the identity of the manufacturer. E&OE.



Traxxas 1/18th Scale Defender

Watch them go... www.britpart.com/traxxas-18



- DA3642** TRX-4M Defender 1:18 Blue
- DA3643** TRX-4M Defender 1:18 Grey
- DA3644** LED Light Set

Big Fun And Adventure In A Smaller Trx-4

Introducing TRX-4M, a new way to experience all the fun, adventure, and scale realism of the TRX-4 in a 1/18 platform. TRX-4M bridges the gap between the small crawler scene and 1/10 scale quality and performance. Oil-filled shocks, steel frame rails, and a smooth running drivetrain give it true outdoor capability over rocks and through grass and streams. The tight turning radius and precise throttle control give it fantastic indoor manoeuvrability.

The Right Size For Fun

TRX-4M is the perfect size to fit in a backpack for fun on the go. It's small, powerful, and manoeuvrable so just about any space becomes an instant trail or crawling course. Whether it's a mountain of books indoors or a rock garden in the backyard, TRX-4M is always ready for big fun and adventure.

All-Terrain Versatility

TRX-4M is equipped to take on tough off-road terrain with grippy soft-compound tires, precision-engineered 4-link suspension geometry, and smooth oil-filled shocks. High centre ground clearance, big approach angles, and low CG give the TRX-4M impressive capability everywhere it goes.

45° Steering Angle

A full 45° steering angle gives TRX-4M an exceptionally tight turning radius and extreme manoeuvrability in small spaces where every inch counts. A heavy-duty 2065T steering servo delivers powerful steering authority, even on thick carpet.

Oil-Filled GTM™ Shocks

TRX-4M's oil-filled GTM shocks offer smooth suspension damping to keep the wheels firmly

What's In The Box:

- > TRX-4M® Ready-To-Race® model
- > Licensed ABS hard body
- > Titan® 180 87-turn motor
- > ECM-2.5™ Electronic Control Module
- > TQ transmitter
- > 7.4 volt 750mAh 2-cell LiPo battery
- > 2-amp USB fast charger with iD®
- > High quality maintenance tools

What You'll Need:

- > 4 x AA alkaline batteries for the transmitter

Many more images and information can be found online at www.britpart.com

planted on uneven surfaces. The added control also keeps the body from bouncing around on rough terrain for a more realistic driving experience.

Detailed ABS Body With Clipless Mounting

The innovative clipless body removes and installs in just seconds with no clips to lose or frustrating hook and loop tabs. Tough, highly detailed ABS bodies feature moulded-in colour with a deep glossy finish that won't chip or scrape off.

Waterproof Electronics

TRX-4M is the truck that goes where you want to go, without boundaries or restrictions. Only Traxxas' fully-waterproof innovation gives you the freedom to drive through wet grass, puddles, and streams that force others to turn around.

Vehicle Spec

- > Length: 279mm
 - > Front Track: 124mm
 - > Rear Track: 124mm
 - > Ground Clearance: 29mm
 - > Weight (w/o battery): 483g
 - > Height: 135mm
 - > Wheelbase: 155mm
 - > Approach Angle: 52°
 - > Breakover Angle: 45°
 - > Departure Angle: 41°
 - > Shock Length (front and rear): 51mm
 - > Hex Size: 7mm
 - > Wheels (front and rear): 25.4 x 12.5mm
 - > Tyres (front and rear): 57 x 25.4mm
 - > Electronic Control Module: ECM-2.5™ (Combo ESC, Receiver, Lighting Control*)
 - > Motor (electric): Titan® 180 87T
 - > Differential Type: Fully Locked; 2:1 Axle Ratio
 - > Chassis Structure/Material: Steel Ladder Frame with Nylon Composite Crossmembers
 - > Brake Type: Electronic "Hill Hold"
 - > Drive System: Shaft-Driven 4WD
 - > Steering: Axle-Mounted Servo
 - > Radio System: TQ™ 2.4GHz 2-Channel Transmitter
 - > Servo: #2065T Heavy-Duty Waterproof
 - > Skill Level: 1
 - > Battery Tray: 50.5mm L X 31mm W
- *Requires accessory Pro Scale LED Light Kit, sold separately

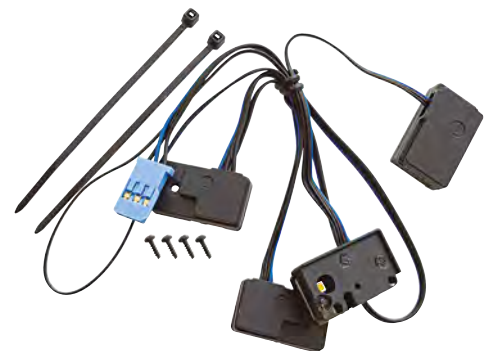
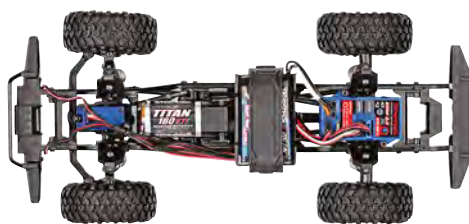

uksales@britpart.co.uk

Available from...

Britpart, The Grove, Craven Arms, Shropshire, SY7 8DA www.britpart.com

Prices include VAT. Part numbers are used for identification purposes only and do not imply or indicate the identity of the manufacturer. E&OE.



AVM Free Wheeling Hubs



Price from...

DA4541
Series 1, 2, 2A & 3 10 Spline

DA4542
Series 1, 2, 2A & 3 24 Spline

DA4543
Defender 90, 110 & 130 300Tdi onwards
Discovery 1 - 300Tdi onwards
(Not compatible with alloy wheels that do not fit around the drive flange).

DA4544
90, 110 & 130 - up to and including 200Tdi
(Not compatible with alloy wheels that do not fit around the drive flange).

AVM freewheeling hubs serve as a robust, reliable, and superior substitute for the hubs originally installed on your vehicle. They're utilized to either connect or disconnect the front drive shaft assembly on part-time 4WD vehicles, but can also be retrofitted to permanent 4WD models with stationary hubs to prevent unnecessary differential spinning and the subsequent wear it incurs. They are also a very useful in the event that you break a front drive shaft on a Series vehicle. Simply disengage the front hubs, put your transfer box back in the 2WD position and you can then drive home.

Each front driveshaft's outermost point has a splined section over which the new hubs inner drive member is fixed. Surrounding this is an outer drive member, which is linked to the wheel, with a clutch functioning as a separator. The clutch engagement is facilitated by slanted grooves cut within the freewheeling hub control knob on the exterior.

By shifting the knob from '4x2' to '4x4', the clutch is mobilized, causing the inner and outer drive member to interlock. For regular road use or driving on firm surfaces, activating 4WD is unnecessary, and the hubs should remain in the free state. However, if 4WD becomes necessary or is anticipated, the hubs should be switched to the 'lock' position.

Installing AVM hubs is straight forward and they come with a heat-treated steel clutch ring that guarantees flawless torque transmission. Made from materials resistant to corrosion, they ensure proper clutch ring positioning, with fully independent engage/disengage springs. AVM offers a comprehensive assortment of hubs and service kits compatible with most vehicle brands and models.

Double S Sport Exhaust Kits



DA3574
Range Rover Sport - P400 3.0 - 2019 onwards
Sports Kit

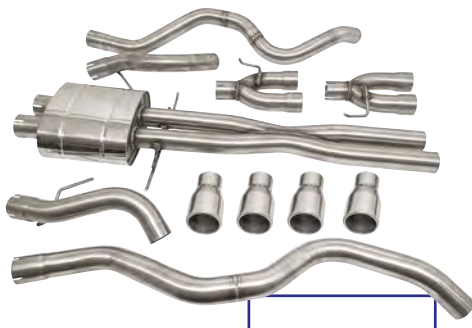

DA3576
Range Rover Sport - SVR - 2015 - 2018
Sports Kit

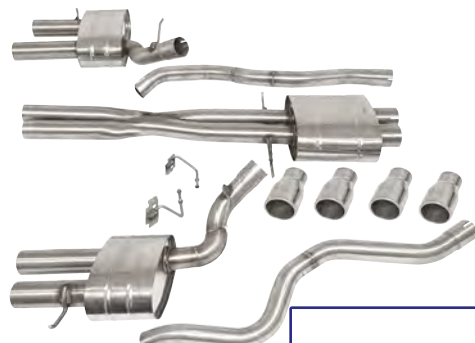

DA3575
Range Rover Sport - 5.0 - 2018 onwards
Sports Kit

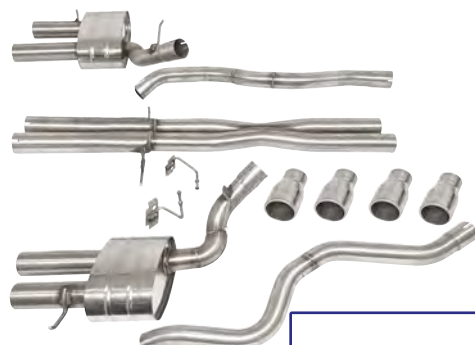

DA3577
Range Rover Sport - SVR - 2018 onwards
Sports Kit

TetraBOOST



DA3671 NEW 1 x 50ml bottle
DA2911 12 x 50ml bottles
TetraBOOST Fuel Life Extender
 TetraBOOST Fuel Life Extender addresses the increasingly common problem of today's petrol 'going off', which causes difficult starting after a period of storage.
 > One 50ml bottle for up to 50 litres of fuel
 > Extends fuel storage life
 > Slowly disperses existing sludge
 > Ideal for winter storage

Price from...

Price from...



DA3672 NEW 1 x 50ml bottle
DA2912 12 x 50ml bottles
TetraBOOST E-Guard Road
 TetraBOOST E-Guard Road is a potassium-based lead replacement, octane booster and ethanol corrosion inhibitor. Designed for cars without hardened valve seats, to give protection from problems resulting from modern ethanolised petrol.
 > One 50ml bottle for up to 50 litres of fuel.
 > Protects against ethanol induced corrosion
 > Inhibits valve seat recession
 > Raises octane by up to 2 points

Exhaust Gasket



DA8602
Replacement exhaust gasket for DA4359

Price from...

Track Rod Clamp Kit



DA3652
Track Rod Clamp Kit

Price from...

uksales@britpart.co.uk

Available from...

Britpart, The Grove, Craven Arms, Shropshire, SY7 8DA www.britpart.com

Prices include VAT. Part numbers are used for identification purposes only and do not imply or indicate the identity of the manufacturer. E&OE.



XS Suspension Arms Air Spring Conversion Kit



LR051592G

Discovery 4
Rear - lower
RHS

LR051594G

Discovery 4
Rear - lower
LHS



DA3517

**Air Spring
Conversion Kit**

Discovery 3
Discovery 4
Range Rover Sport -
2005 - 2013 - without
ACE

Kit includes -
A loom to fit
Discovery 3 & Range
Rover Sport - 2005
- 2009

A loom to fit
Discovery 4 & Range
Rover Sport - 2010
- 2013



Performance Brake Disc

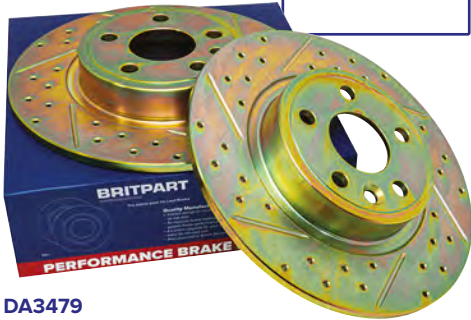

DA3479

Corresponds to LR072016
Range Rover Evoque - 2012 - 2018
Rear



An air-to-coil conversion kit designed to eliminate the risks of costly air suspension repairs and the possibility of getting stuck due to a failure in the air suspension. This comprehensive package includes pre-assembled front and rear struts, an advanced air suspension override module, and bespoke wiring harnesses specific to your model.

The kit is designed to maintain the same ride height as the former air-based system while offering excellent load-bearing properties. Ride comfort and manoeuvrability remain uncompromised. Additionally, the override module is engineered to preserve all original electronic functions, including Terrain Response, Headlight Adjustment, and the functions of the Information Screen, among others.

Carpet Mat Set



VPLKS0632PVJLR

Contour Premium Mat Set
Range Rover Sport - 2023 onwards
Range Rover - 2022 onwards
RHD
Black
Standard wheel base



Universal Replacement Bulkheads

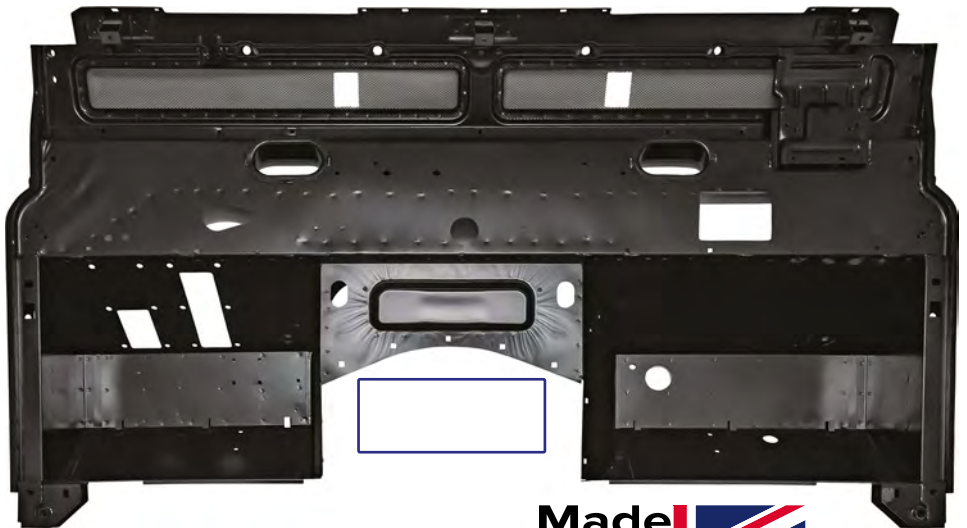

Universal Replacement Bulkhead

Defender - 1983 - 2006
DA2970 Right hand drive
DA2971 Left hand drive **NOW AVAILABLE**

Loose brackets are included in the kit to allow for model year differences made by Land Rover over the years. Some minor modifications to the transmission tunnel may be needed to accommodate different transmission tunnels, with the V8 for example. Made in the West Midlands just like a Land Rover.



uksales@britpart.co.uk

Available from...

Britpart, The Grove, Craven Arms,
Shropshire, SY7 8DA www.britpart.com

Prices include VAT. Part numbers are used for identification purposes only and do not imply or indicate the identity of the manufacturer. E&OE.



Brembo Braking Products



official partner



LR017953BR

Defender 2007 - 2016
Rear
Pair
Solid

Price from...

LR161899BR

Defender - 2020 onwards
Discovery 5
Range Rover Sport - 2014 - 2022
Range Rover - 2013 - 2023

Rear
Single
Vented
SDB000211BR
Range Rover - 2002 - 2009

Rear
Single
Solid
SDB000624BR
Discovery 4
Range Rover Sport - 2005 - 2013
Front
Single
Vented

LR160069BR

Range Rover Sport - 2014 - 2022
Range Rover - 2013 - 2023
Front

LR147981BR

Range Rover Sport - 2014 - 2022
Range Rover - 2013 - 2023
Rear

LR161897BR

Range Rover Sport - 2014 - 2022
Range Rover - 2013 - 2023
Rear
Pair
Vented

LR161893BR

Range Rover Sport - 2014 - 2022
Range Rover - 2013 - 2023
Front
Single
Vented

LR161894BR

Defender - 2020 onwards
Discovery 5
Range Rover Sport - 2014 - 2022
Range Rover - 2013 - 2023
Front
Single
Vented

Eezibleed Kit



DA6174

Eezibleed Kit

Easy fluid replacement system using air pressure from the spare wheel to bleed brake and clutch hydraulics. Safe to use, the one-way flow mechanism and airtight seal on the reservoir ensures fast fluid replacement with no contamination. There is no need for pedal pumping which avoids the risk of damaging the master cylinder seal. The versatile kit includes four screw caps (25, 27, 44-45 and 46mm) as well as three hoses, making it easy to connect Eezibleed to a wide variety of vehicles.

- > Suitable for single handed operation. Uses the air pressure from a spare tyre to effortlessly bleed hydraulic systems.
- > Can be used successfully on the following systems: tandem master cylinders without sensors, tandem reservoirs, slave servos and vacuum servos.
- > Includes a range of cap and seal sizes: 25mm (Lockheed systems), 27mm (certain VAG systems), 44/45mm (metal Girling reservoirs and all ATE systems) and 46mm (certain Girling systems).
- > Kit contains: pressure bottle (for new brake fluid), bottle cap assembly, bleed tube set, five cap and seal sets, brass reservoir cap fitting, two fibre washers, lock nut and hook.

Lucas & Girling Classic



YUF101490LUCAS

Hazard Switch
90/110 & 130 - up to 2006

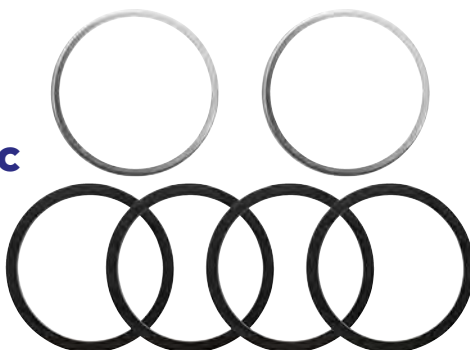

8G8587LGIRLING

Rear Brake Caliper Piston Seal Kit
90 - up to 2016

Classic Horn Push

DA3921

Classic Horn Push

The polished horn push fits the traditional Mountney boss kits - DA4661/DA4659/DA4660. The perfect enhancement for the Mountney classic wood rim steering wheels - DA3920/DA4876/DA4877.



uksales@britpart.co.uk

Available from...

Britpart, The Grove, Craven Arms, Shropshire, SY7 8DA www.britpart.com

Prices include VAT. Part numbers are used for identification purposes only and do not imply or indicate the identity of the manufacturer. E&OE.



Polybush Rear Lamp Boot



DA3648
Polybush Rear Lamp Boot

The Defender's rear lights have no protection from water ingress via the rear of the vehicle. Anything from rain to wading can cause damage, which leads to rust and corrosion of the electrical system, resulting in short circuits and malfunctioning lights and indicators.

The Polybush Rear Lamp Boot saves your Defender from corrosion, its designed to specifically to fit around the O.E lights on your Defender. The boot provides an effective barrier against water ingress and wheel spray, protecting the connections and preventing rust and corrosion



Light not supplied

ensuring that the rear lights and indicators remain functional, improving visibility and reducing the risk of accidents. The boot is made from a durable and long-lasting Polyurethane, which is unaffected by oil, fuel, and road contaminants.

Unlike rubber, Polyurethane remains flexible and pliable, ensuring that the boot maintains its protective qualities for decades. Installation of the boot is a straightforward process. Cost-effective as it saves Defender owners time and money by eliminating the need for expensive repairs due to water damage. The boot is an affordable and practical solution that provides peace of mind for Land Rover Defender owners who enjoy off-road adventures.

Norma Fuel Line Repair Kit

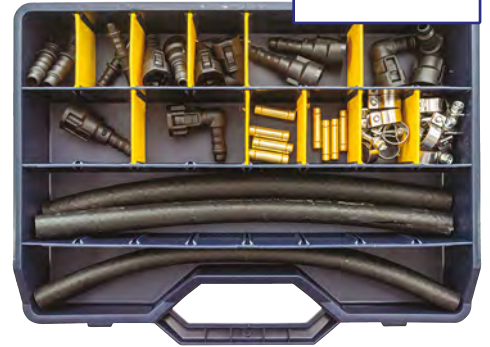

DA3611
Norma® Fuel Line Repair Kit

One stop solution to repair defective fuel lines in under five minutes

- > Economical solution to repair defective spots instead of replacing complete fuel lines Access to OEM quality materials
- > Easy identification of the components within the kit with the help of product descriptions
- > Standard quick connector spigot connection as per SAE J2044

Safety aspect:

- > NORMAQUICK® S connector cannot be opened under pressure
- > Very high pull-off forces of quick connectors due to four locking arms ABA Mini provides excellent clamping force compared to screwless clamps

The kit contains:

- Qty x 2 - S NW 3/8" - 5/16" - 0° | Adapter
- Qty x 2 - S NW 5/16" - 6mm - 0° | Adapter
- Qty x 2 - S NW 5/16" - 6mm - 0°
- Qty x 2 - S NW 5/16" - 6mm - 90°
- Qty x 1 - S NW 9.89mm - 8mm - 0°
- Qty x 1 - S NW 9.89mm - 8mm - 90°
- Qty x 2 - S NW 3/8" - 5/16" - 0°
- Qty x 2 - S NW 3/8" - 5/16" - 90°
- Qty x 4 - Sleeve - Ø 6 mm
- Qty x 4 - Sleeve - Ø 8 mm
- Qty x 2 - Rubber hose - ID 8 mm
- Qty x 2 - Rubber hose - ID 10 mm
- Qty x 8 - ABA Mini 14/9 W4
- Qty x 8 - ABA Mini 16/9 W4

AJ200 204DTD Pistons



DA3425
Piston - 0.010"/0.25mm
AJ200 204DTD



DA3556
Piston - 0.020"/0.50mm
AJ200 204DTD

Defender Headrests



DA5695
NAS
Vinyl twill main panel with black vinyl border



MWC1010
Black



MWC5628LCS
Grey



AWR5708RPI
Vinyl Twill

Head Set

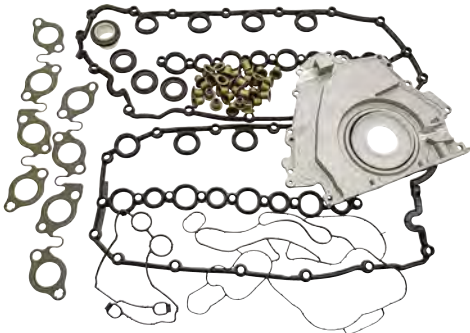

DA5181
3.6 TdV8
Head Set - Less Head Gasket

Defender Tow Bar



VPLET0272
Defender 2020
Tow bar with detachable swan neck tow ball. Excludes wiring.

Loadspace Mat

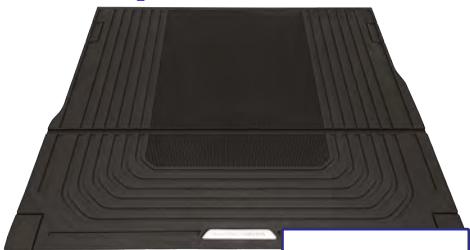

VPLXS0672LR
Loadspace Mat
Range Rover Sport - 2023 onwards

Side Steps



VLPRP0530
Fixed Side Step
Discovery 5

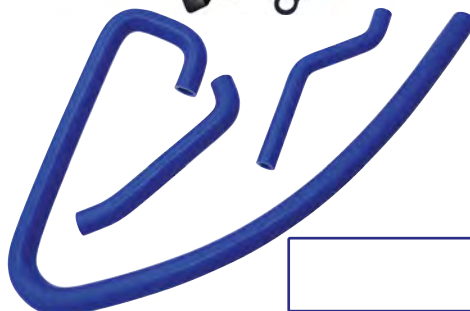

DA3384
Breather Hose Kit
Discovery 1 - 300Tdi
3 piece kit

Silicone Hose Kits



DA4899
Intercooler to Throttle Body Kit
Discovery Sport - 2015 onwards
Range Rover Evoque - 2012 - 2018

Mudflaps



VPLXP0527LR
Range Rover Sport
- 2023 onwards - Non-Sport/Dynamic Models
Front



VPLXP0529LR
Range Rover Sport
- 2023 onwards
Rear



VPLVP0065LR
Range Rover Evoque
- 2012 - 2018
Front

uksales@britpart.co.uk

Available from...

Britpart, The Grove, Craven Arms,
Shropshire, SY7 8DA www.britpart.com

Prices include VAT. Part numbers are used for identification purposes only and do not imply or indicate the identity of the manufacturer. E&OE.

